

PL16-INITIAL LIFT

Fast+slow gear selector / Cold store -30°C

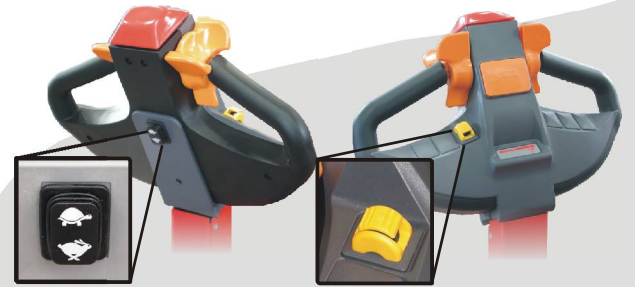

Roller to control the descending speed of the Forks

The possibility to load up to two pallets and to cross in easy way slope and ramp



QUICK BATTERY CHANGE
AVAILABLE and
"PLATFORM" VERSION

Pegasolift 

CE

PL16-INITIAL LIFT Series

Double-deck stacker with Initial Lift of the front legs



Via del Lavoro 14 - 37047 San Bonifacio (Verona - Italy)
Tel. (0039) 045/7665570 - Fax: (0039) 045/7665698
www.pegasolift.com

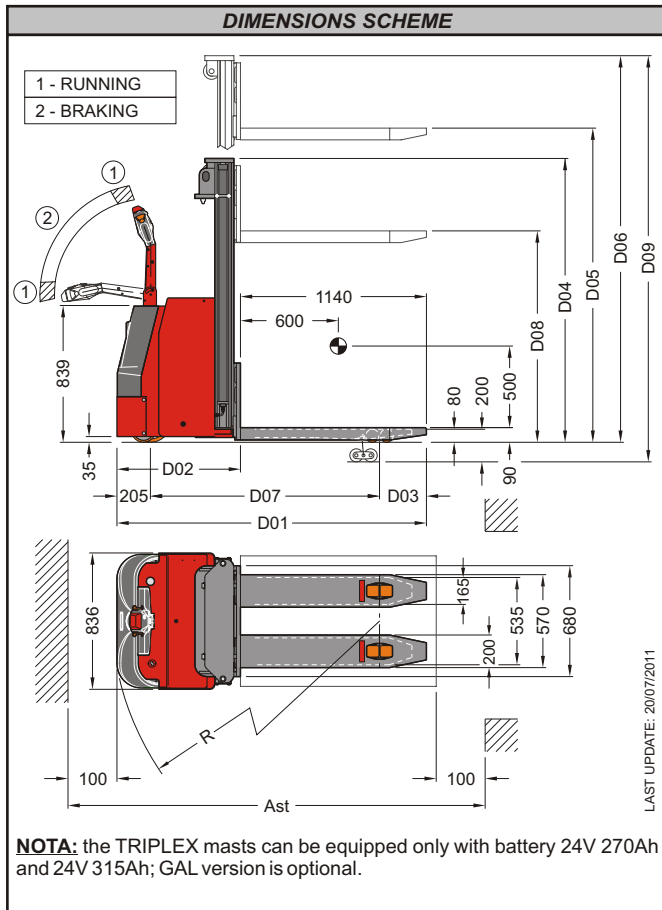

GENERAL SPECIFICATIONS	
MODEL	PL16-INITIAL LIFT
Nominal load capacity (up to a lifting height of 2,5 m)	1600 kg
Combined load capacities (2 Europallets)	800 kg on front legs + 800 kg on forks (up to 2,5 m)
Axle load with load	front 2 / 7 rear 5 / 7
Axle load without load	front 3 / 4 rear 1 / 4
Double front rollers size (polyurethane)	ø 80 × 70
Drive wheel size (polyurethane)	ø 250 × 79
Additional wheel size (polyurethane)	ø 150 × 50
Front track	440
Rear track	560
Height of tiller in gear position (brake releasing)	min 1000 max 1315
Travel speed	with load 5,5 km/h without load 6,0 km/h
Max gradeability	with load 9% without load 18%
Brake	Electromagnetic
Electronic control type	Mosfet 24V 200A
Traction motor power (series excite system)	1400 W
Pump motor power	3000W
Battery box size (L × W × H)	220 × 820 × 565

INTECHANGEABLE MASTS SPECIFICATIONS

MAST NOMINATION	H = 1,6 m	H = 2,5 m	H = 2,9 m	H = 3,2 m	H = 3,6 m	H = 4,2 m	H = 4,5 m	H = 4,5 m	H = 5,0 m	H = 5,5 m	
Mast type	Simplex	Duplex	Duplex	Duplex	Duplex	Duplex	Duplex	Triplex	Triplex	Triplex	
Distance between axle	D07	1404						1454			
Total length	D01	1962	1947						1964		
Length with forks shoulder	D02	822	807						824		
Front distance between axle	D03	302	287						254		
Steering radius	R	1648	1633						1650		
Working isle width	Ast	2171	2156						2173		
Min forks height	90										
Min front legs height	80										
Max lifting height of front legs	200										
Lifting stroke of front legs	120										
Lifting height (1)	D05	1600	2500	2900	3200	3600	4200	4500	4500	5000	5500
GAL lifting height (OPTIONAL)	D08	-	-	-	1600	1800	2100	2255	1658	1824	1990
Mast lowered height (1)	D04	1990	1745	1945	2095	2295	2595	2750	2130	2296	2462
Mast extended height (1)	D06	-	2950	3350	3650	4050	4650	4950	5070	5570	6070
Max extended height of the stacker (2)	D09	2110	3070	3470	3770	4170	4770	5070	5190	5690	6190
Weight (without battery)		623 kg	754 kg	775 kg	785 kg	812 kg	838 kg	865 kg	984 kg	1014 kg	1044 kg
Lifting speed	with load	0,10 m/s	0,10 m/s	0,10 m/s	0,10 m/s	0,10 m/s	0,10 m/s	0,10 m/s	0,10 m/s	0,10 m/s	0,10 m/s
	without load	0,12 m/s	0,12 m/s	0,12 m/s	0,12 m/s	0,12 m/s	0,12 m/s	0,12 m/s	0,12 m/s	0,12 m/s	0,12 m/s
Lowering speed	with load	0,13 m/s	0,13 m/s	0,13 m/s	0,13 m/s	0,13 m/s	0,13 m/s	0,13 m/s	0,13 m/s	0,13 m/s	0,13 m/s
	without load	0,09 m/s	0,09 m/s	0,09 m/s	0,09 m/s	0,09 m/s	0,09 m/s	0,09 m/s	0,09 m/s	0,09 m/s	0,09 m/s
Forks size	200 × 76 × 1140										
Front legs size	165 × 51 × 1050										

PL16-INITIAL LIFT SERIES - BATTERIES AVAILABLE AND TOTAL COMBINED RESIDUAL CAPACITY AT THE MAX LIFTING HEIGHT

Traction battery 24V 160Ah (167 kg)	1600 kg	1600 kg	1140 kg	1010 kg	870 kg	640 kg	515 kg	N.D.	N.D.	N.D.
Traction battery 24V 180Ah (188 kg)	1600 kg	1600 kg	1210 kg	1065 kg	915 kg	675 kg	535 kg	N.D.	N.D.	N.D.
Traction battery 24V 240Ah (219 kg)	1600 kg	1600 kg	1250 kg	1110 kg	960 kg	705 kg	570 kg	N.D.	N.D.	N.D.
Traction battery 24V 270Ah (251 kg)	1600 kg	1600 kg	1300 kg	1155 kg	1000 kg	730 kg	590 kg	1083 kg	950 kg	800 kg.
Traction battery 24V 315Ah (288 kg)	1600 kg	1600 kg	1345 kg	1195 kg	1030 kg	750 kg	610 kg	1098 kg	965 kg	820 kg.

NOTE (1): Without Initial Lift (2): With extended mast and Initial Lift

PL16-INITIAL LIFT series is double-deck stacker: it permits to pick up two Europallets, one upon the other, via mast and support front legs. Available with DUPLEX and TRIPLEX mast also in GAL version (optional), can be equipped with various optional as: the pump for quick lifting of the forks, lateral door for quick battery change, drive wheel ring in trail-proof soft polyurethane with carved tread, battery charge indicator with LCD hours counter and block of the forks with flat battery, up to the cold store version at -30°C.