



Doosan Infracore  
Forklifts

# TECHNICAL SPECIFICATIONS

## Pneumatic Forklift Trucks

G20G / G25G / G30G

D20G / D25G / D30G

2,000kg to 3,000kg Capacity



# 2,000/2,500/3,000 kg Capacities

Engine Powered Forklift Trucks  
Pneumatic Tire Diesel, LP, Gas

## MAIN VEHICLE SPECIFICATIONS

CHARACTERISTICS	2	Model		D20G	D25G	D30G	G20G	G25G	G30G		
	3	Capacity	at rated load center	kg	2000	2500	3000	2000	2500	3000	
	4	Load center	Distance	mm	500			500			
	5	Power type	Diesel, Gasoline, Lp - gas		Diesel			LP, Gas			
	6	Operator type	Stand - on, Driver - seated		Driver Seated			Driver Seated			
	7	Tire type	C = cushion, P = pneumatic		P			P			
	8	Wheels(x = driven)	Number, front / rear		x 2 / 2			x 2 / 2			
	DIMENSIONS	9	Lift with STD	Max. fork height	mm	3000	3000	3000	3000	3000	3000
10		Two-stage mast	Free lift	mm	150	150	156	150	150	156	
12		Fork carriage	ISO class		II	II	III	II	II	III	
13		Forks	Thickness x width x length	mm	45 × 100 × 1050	45 × 100 × 1050	45 × 122 × 1050	45 × 100 × 1050	45 × 100 × 1050	45 × 122 × 1050	
		Fork spacing	Minimum x maximum	mm	250 × 1000	250 × 1000	272 × 1042	250 × 1000	250 × 1000	272 × 1042	
14		Tilt of mast	Forward / backward	deg	6 / 12	6 / 12	6 / 12	6 / 12	6 / 12	6/12	
15		Overall Dimensions	Length to fork face	mm	2520	2585	2662	2520	2585	2662	
16			Width	mm	1165	1165	1228	1165	1165	1228	
17			Mast lowered height	mm	2038	2038	2053	2038	2038	2053	
18			Mast extended height	mm	4271	4271	4280	4271	4271	4280	
19			Overhead guard height	mm	2143	2143	2160	2143	2143	2160	
20			Seat height	mm	1168	1168	1185	1168	1168	1185	
21		Turning radius	Minimum outside	mm	2250	2300	2375	2250	2300	2375	
22		LMC	Load Moment Center	mm	467	467	482	467	467	482	
23	Aisle 90° stacking	add load length	mm	2717	2767	2857	2717	2767	2857		
23a	Aisle 90° intersecting		mm	2162	2230	2290	2165	2230	2290		
PERFORMANCE	24	Speeds	Travel : loaded / unloaded	km/h	19.5 / 21	19.5 / 21	20 / 21.5	19 / 20	19 / 20	19.5 / 20.5	
	25		Lift : loaded / unloaded	mm/s	520 / 570	510 / 570	490 / 570	500 / 550	500 / 550	500 / 550	
	26		Lowering : loaded / unloaded	mm/s	510 / 460	510 / 460	510 / 460	560 / 580	560 / 580	550 / 580	
	28	Drawbar pull	Loaded at 1.6 km / h	kg	1840	1820	1750	1650	1625	1465	
30	Gradeability	Loaded at 1.6 km / h	%	35	29	24	31	26	20		
WEIGHT	32	Total weight	Unloaded	kg	3570	3940	4460	3480	3850	4320	
	33	Axle load	With load : front / rear	kg	4900 / 670	5650 / 790	6560 / 900	4660 / 820	5400 / 950	6210 / 1110	
			Without load : front / rear	kg	1690 / 1880	1650 / 2290	1750 / 2710	1360 / 2120	1500 / 2350	1680 / 2640	
34											
CHASSIS	35		Number of front / rear		2 / 2	2 / 2	2 / 2	2 / 2	2 / 2	2 / 2	
	36	Tires	Size, front		7.00 x 12 - 12PR	7.00 x 12 - 12PR	28 x 9 - 15 - 12PR	7.00-12-12PR	7.00-12-12PR	28x9-15-12PR	
			Size, rear		6.00 x 9 - 10PR	6.00 x 9 - 10PR	6.50 x 10 - 10PR	6.00-9-10PR	6.00-9-10PR	6.50-10-10PR	
	38	Wheelbase	Distance	mm	1650	1650	1650	1650	1650	1650	
	39	Tread width	Front	mm	970	970	1000	970	970	1000	
			Rear	mm	980	980	980	980	980	980	
	40	Ground	Loaded	at lowest point	mm	100	100	118	100	100	118
	41	Clearance		at center of truck	mm	113	113	132	113	113	132
42	Brakes	Service(Foot)		hydraulic	hydraulic	hydraulic	hydraulic	hydraulic	hydraulic		
43		Parking(Hand)		mech	mech	mech	mech	mech	mech		
POWER TRAIN	45	Battery	Voltage / ampere - hour	V-AH	12 / 90	12 / 90	12 / 90	12 / 65	12 / 65	12 / 65	
	50	Engine	Model		4TNE98	4TNE98	4TNE98	G424F	G424F	G424F	
			Rated Power(DIN)	HP / rpm		59 / 2300	59 / 2300	59 / 2300	62 / 2550	62 / 2550	62 / 2550
				kW / rpm		43.7 / 2300	43.7 / 2300	43.7 / 2300	46.2 / 2550	46.2 / 2550	46.2 / 2550
			51	Maximum Torque	N-m / rpm		181 / 1600	181 / 1600	181 / 1600	181 / 2200	181 / 2200
	52	Cylinders / displacement	cc		4 / 3319	4 / 3319	4 / 3319	4 / 2405	4 / 2405	4 / 2405	
	55	Transmission	Type		powershift	powershift	powershift	powershift	powershift	powershift	
Number of speeds				1 / 1	1 / 1	1 / 1	1 / 1	1 / 1	1 / 1		
57	Relief pressure	System	bar	181	195	216	182	182	210		
		Attachments	bar	156	156	156	160	160	160		

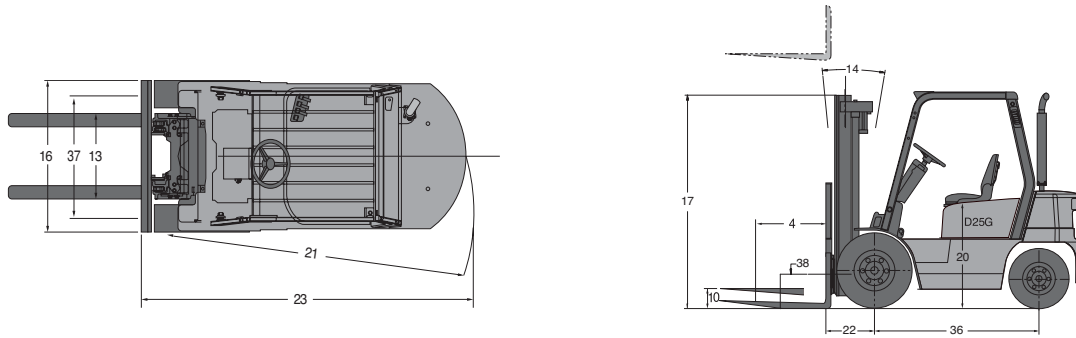

## MAST SPECIFICATIONS and RATED CAPACITIES

### D/G20G

Mast type	Maximum Fork Height	Maximum Lowered Height	Fully Extended Height	Free Lift	Rated Load Capacities					
					D(G)20G					
					Tilt Angle				Load Capacities	
					Single Pneu.		Double Pneu		Single Pneu.	Double Pneu
FWD	BWD	FWD	BWD	LC 500mm	LC 500mm					
deg										
kg										
STD	3000	2030	4230	150	6	12	6	12	2000	2000
	3300	2180	4530	150	6	12	6	12	2000	2000
	3500	2280	4730	150	6	12	6	12	2000	2000
	4000	2580	5330	150	6	12	6	12	2000	2000
	4500	2830	5830	150	6	6	6	12	2000	2000
FF	3210	2130	4460	925	6	12	6	12	2000	2000
	4270	1990	5540	785	6	6	6	12	1975	1950
FFT	4710	2130	5960	925	6	6	6	12	1800	1875
	5540	2480	6785	1275	6	6	6	12	1050	1750
	5990	2630	7235	1425	6	6	6	6	775	1675

### D/G25G

Mast type	Maximum Fork Height	Maximum Lowered Height	Fully Extended Height	Free Lift	Rated Load Capacities					
					D(G)25G					
					Tilt Angle				Load Capacities	
					Single Pneu.		Double Pneu		Single Pneu.	Double Pneu
FWD	BWD	FWD	BWD	LC 500mm	LC 500mm					
deg										
kg										
STD	3000	2030	4230	150	6	12	6	12	2500	2500
	3300	2180	4530	150	6	12	6	12	2500	2500
	3500	2280	4730	150	6	12	6	12	2500	2500
	4000	2580	5330	150	6	6	6	12	2500	2500
	4500	2830	5830	150	6	6	6	12	1900	2500
FF	3210	2130	4460	925	6	12	6	12	2500	2500
	4270	1990	5540	785	6	6	6	12	2250	2475
FFT	4710	2130	5960	925	6	6	6	12	1700	2375
	5540	2480	6785	1275	6	4	6	6	1125	2225
	5990	2630	7235	1425	6	4	6	6	850	2150

### D/G30G

Mast type	Maximum Fork Height	Maximum Lowered Height	Fully Extended Height	Free Lift	Rated Load Capacities					
					D(G)30G					
					Tilt Angle				Load Capacities	
					Single Pneu.		Double Pneu		Single Pneu.	Double Pneu
FWD	BWD	FWD	BWD	LC 500mm	LC 500mm					
deg										
kg										
STD	3000	2045	4230	158	6	12	6	12	3000	3000
	3300	2195	4530	158	6	12	6	12	3000	3000
	3500	2295	4730	158	6	12	6	12	3000	3000
	4000	2595	5330	158	6	6	6	12	3000	3000
	4500	2845	5830	158	6	4	6	12	2600	2975
FF	3210	2145	4460	940	6	12	6	12	3000	3000
	4270	2005	5540	800	6	6	6	12	2850	2925
FFT	4710	2145	5960	940	6	4	6	12	2425	2825
	5540	2495	6785	1290	6	4	6	6	1375	2650
	5990	2645	7235	1440	6	4	6	4	975	2550



ISO 9001

ISO 14001

# GX



**G20G / G25G / G30G**  
2,000kg 2,500kg 3,000kg  
Gas, LPG, Pneumatic Tire



**D20G / D25G / D30G**  
2,000kg 2,500kg 3,000kg  
Diesel, Pneumatic Tire



PSC0711C0 (Nov.2007)



**Doosan Infracore**  
Forklifts

**Head Office** : 7-11, Hwasu-Dong, Dong-Gu, Incheon, Korea.  
Tel : 82-32-211-5011 Fax : 82-32-211-5412  
**Seoul Office** : 22nd floor, Doosan Tower Bldg, Euljiro 6-Ga  
Jung-Gu, Seoul, Korea.  
Tel : 82-2-3398-8633 Fax : 82-2-3398-8619  
**Web site** : <http://iv.doosaninfracore.co.kr/eng>

AUTHORIZED DEALER

Product and specifications are subject to improvement and change without notice.